

Versa-Filter System User's Guide and Specifications

Digital Filter Systems with Analog I/O

Key Features

- Linear Phase LP, HP, BP, and BS Filters
- Notch and Inverse-Notch Filters
- User-specified FIR Filter Coefficients downloadable
- 1 Hz Tuning Resolution
- Two Independent Channels
- DC to 20KHz with 0.04% THD max.
- Internal White Noise Generator
- Programmable Input Amplifiers
- Gain Adjustable from 0 to ± 100.00 in 0.01 steps
- Liquid Crystal Display (LCD)
- Rotary Encoder front panel control
- Store and Recall Filter Settings FLASH Memory
- RS-232 Serial Interface for remote PC control
- VU Level Meters for Input and Output level display
- External 120VAC wall-mount power supply included (95-250VAC universal power supply optional)
- Size: 10" wide x 2.75" high x 8" deep



Overview

The Versa-Filter System is versatile, high performance, digital filter and signal conditioning system with analog inputs and outputs. These systems feature two independent 0 to 20KHz channels, programmable gain amplifiers, a liquid crystal display, and RS-232 serial control interfaces. A digital signal processor (DSP) performs a multitude of functions including low-pass, high-pass, band-pass, band-stop, and notch filtering with a 1Hz tuning resolution.

Table 1: Ordering Information:

Order Code	Description
2chVFS-Bench	2-channel, 0 to 20KHz bench-top Versa-Filter System

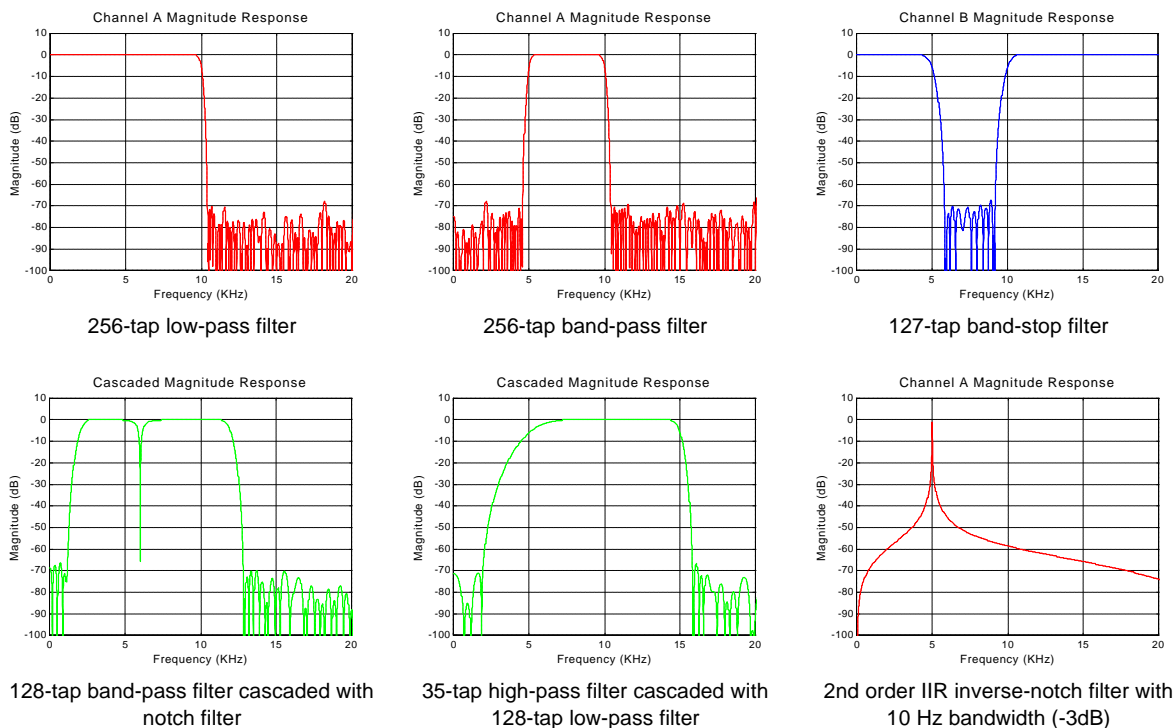

Figure 1: Filter Response Examples

Signal Processing Solutions, Inc. products are not intended for use in life support appliances, devices or systems and such use is prohibited without written consent of the appropriate company officer. SPS reserves the right to modify this product without notice.

Applications

The Versa-Filter system is a compact, flexible replacements for traditional analog filters and have wide applications in the following areas:

- **Signal Conditioning**
- **Data Acquisition Systems**
- **Anti-Alias Filters**
- **Signal Reconstruction**
- **Automatic Test Equipment Applications**
- **Telecommunications Equipment**
- **Speech and Audio Processing**
- **Test and Measurement Equipment**
- **Aerospace and Military Systems**
- **Scientific Equipment**

Sample Filter Responses

The Versa-Filter system performs filtering on two independent channels simultaneously or a single channel with a higher maximum filter order. Filter response examples are shown in Figure 1. The 256-tap low-pass filter and band-pass filter use the maximum number of taps supported by the system in single channel mode. The transition widths of these 256-tap FIR filters are about 400Hz when operating at the 48KHz sampling rate. The frequency transition widths are independent of the cutoff frequency setting and the filter type (for LP, HP, BP, and BS). Shorter filter lengths yield wider transition widths as seen in the 127-tap band-stop filter response curves.

In dual channel mode, the two filters may be set to different functions and internally cascaded to achieve a wide variety of responses. The figure shows a band-pass filter cascaded with a notch filter, and a reduced-order high-pass filter cascaded with a low-pass filter. The inverse-notch is a second-order IIR band-pass filter, shown with a 10 Hz bandwidth. An increase in stopband attenuation may be achieved by cascading two filters of the same type (not shown in the figure).

General Description

The standard tunable low-pass, high-pass, band-pass, and band-stop filters are realized with linear phase, finite impulse response (FIR) digital filters. Linear phase filter have a constant time delay, independent of the frequency setting. All filters have a 1Hz tuning resolution on all band edges. The filter type, filter order, and gain may be set independently for each channel. The system supports filter orders from 3 to 128 taps in dual channel mode, or up to 256 taps in single channel mode, giving a filter transition width of 400Hz resulting in a shape factor of 1-to-1.04 for a 10KHz low-pass filter. The notch and inverse-notch filters are second-order infinite impulse response (IIR) filters with adjustable center frequencies and bandwidths.

The filter parameters are set with the knob on the front panel or through the standard RS-232 serial interface using simple ASCII commands as described in the Serial Command Format section below. A PC may be used to control one or multiple systems using a single RS-232 serial output. The Versa-Filter systems also have an RS-232 output that can be daisy-chained to other Versa-Filter systems. All systems on the serial interface may be broadcast common commands or individual systems may be addressed by their own unique serial number.

The filter coefficients are computed by the on-board DSP in real-time as the frequency and filter order parameters are adjusted. The LCD shows the Versa-Filter parameter settings or the peak I/O signal levels with bar-graph type VU-meters.

An internal FLASH memory is used to store all system settings to one of five memory locations (0 to 4). When power is first applied, the settings from memory location 0 are automatically recalled. The system's firmware resides in FLASH memory so any firmware updates may be downloaded.

The sampling rate of the Versa-Filter may be set to 48KHz, yielding a 20KHz bandwidth, or it may be set to 8KHz for a 3.3KHz bandwidth. The tunable FIR filters have about 70dB or better stop-band attenuation with a 400Hz transition width for the 256 tap filters (70Hz transition for the lower sampling rate).

Versa-Filter system Parameters

The LCD displays the parameter name on the left and the parameter value on the right: ‘parameter: value’. When the cursor is on the left side of the LCD, turning the knob selects the parameter to be adjusted. When the cursor is on the right side of the LCD, turning the knob will change the parameter’s value and immediately update the Versa-Filter’s setting. Pressing the knob repeatedly will position the cursor to the desired location on the LCD. Holding the knob down while turning it will also position the cursor.

The menu is arranged in a linear structure. The first menu entry is the Versa-Filter’s function parameter: “**FUNC:**”, which may have values such as “**LowPass**” or “**BandPass**”. The next menu entry after: “**FUNC:LowPass**” will be the parameters associated with the low-pass function: “**LPfcut**”, “**LPorder**”, and “**LPgain**”. After the filter function and associated parameters, the Versa-Filter’s menu includes the global parameters. The complete list of parameters are shown in Table 2 and full parameter descriptions follow in the next section.

If the system’s “**Mode:**” is set to “**A&BSeparate**”, then individual “**aFUNC:**” and “**bFUNC:**” function parameters are displayed so that the desired function can be set for each channel. Otherwise, a space will appear before the **FUNC**, indicating that both channels are set to the same function.

The frequency settings for the band-pass and band-stop filter may be changed in several ways. The filter band edge frequencies for these filters can be set directly with f1 and f2 parameters or they may be specified indirectly by setting the center frequency and the bandwidth parameters. Making an adjustment of any one of these parameters recalculates the others.

Table 2: system parameters as shown on Versa-Filter display. (Valid options shown in square brackets)

Function Parameter		Global Parameters
[a, b, space] FUNC: [NoFunc, AllPass, LowPass, HighPass, BandPass, BandStop, Notch, InvNotch, UserFIR]		Levels:in- - out- - RevertToLevels: [Y, N] FullScalln: ##Vpp SampleRate: [8KHz, 48KHz] InputSrc: [Analog, WtNoise] Mode: [A&B Common, A&BSeparate, Ch A Only] Cascade Ch A&B: [Y, N] Master Mode: [Y, N] Initialize: press Store: # press Recall: # press Firmware: Vx.xx Serial No: xxxxxx
Function Sub-Parameters		
NoFunc AllPass APGain: ###.##x LowPass LPfcut: #####Hz LPorder: ###x LPgain: ###.##x HighPass HPfcut: #####Hz HPorder: ###x HPgain: ###.##x	BandPass BPf1: #####Hz BPf2: #####Hz BPfcnt: #####Hz BPfwdth: #####Hz BPorder: ###x BPgain: ###.##x BandStop BSf1: #####Hz BSf2: #####Hz BSfcnt: #####Hz BSfwdth: #####Hz BSorder: ###x BSgain: ###.##x	
	Notch Nfnotch:#####Hz Nfwidth:#####Hz Ngain: ###.##x InvNotch INfcnt: #####Hz INfwdth:#####Hz INgain: ###.##x UserFIR UForder: ### UFtap: Ufgain: ###.##x	

Function Parameter Descriptions

The parameters described in this section pertain to the Versa-Filter’s function selection and to the parameters associated with the function.

[a, b, space] FUNC: [NoFunc, AllPass, LowPass, HighPass, BandPass, BandStop, Notch, InvNotch, UserFIR]

This parameter sets the filter function for the specified channel. If a leading “**a**” is displayed on the LCD, then the function or parameter setting pertains to channel A. Similarly, a leading “**b**” indicates channel B. If there is a leading space, then both

channels are set to the same function. There are three separate memory spaces for function parameter storage: channel A, channel B, and the common space.

NoFunc. The no-function setting is the equivalent to muting the outputs. No signal will be present at the system outputs.

AllPass. The signal from the A/Ds are passed without filtering through the DSP and out of the D/As. Since the delta-sigma A/Ds and D/As have built-in anti-aliasing filters the system's bandwidth is limited. The net result is that the system looks like a low-pass filter with a -6dB point at a frequency of about 21.6KHz for the 48KHz sampling rate.

APGain: ###.##x

Setting the Gain sets the overall end-to-end gain of the current channel. The gain factor may be set from -100.00 to $+100.00$ times in steps of 0.01 . A negative gain setting inverts the signal. The VU meters are not affected by the gain setting. The gain control is realized with a combination of digital signal multiplication and output attenuator setting so that the maximum dynamic range is preserved in the signal. The DSP automatically computes the optimal gain distribution so that maximum D/A loading is achieved.

LowPass. Selects the digital FIR low-pass filter that passes signals with a frequency from DC to some specified cutoff frequency.

LPfcut: #####Hz

Specifies the cutoff frequency of the low-pass filter. This is the frequency where the gain is $1/2$ (-6dB) of the nominal gain. See Table 8 for parameter limits.

LPorder: ###x

Specifies the filter order of the FIR low-pass filter. Filter orders supported are from 3 to 128 taps for 2-channel mode, and 3 to 256 taps for 1-channel mode.

LPGain: ###.##x

See APGain above.

HighPass. Selects the digital FIR high-pass filter that passes signals with a frequency from some specified cutoff frequency to the bandwidth limits of the A/D and D/A chain, or about 21.6KHz for the 48KHz sampling rate.

HPfcut: #####Hz

Specifies the cutoff frequency of the high-pass filter. This is the frequency where the gain is $1/2$ (-6dB) of the nominal gain. See Table 8 for parameter limits.

HPorder: ###x

Specifies the filter order of the FIR high-pass filter. Filter orders supported are from 3 to 128 taps for 2-channel mode, and 3 to 256 taps for 1-channel mode.

HPGain: ###.##x

See APGain above.

BandPass. Selects the digital FIR band-pass filter that passes signals with frequencies between two specified cutoff frequencies.

BPf1: #####Hz

Specifies the lower cutoff frequency of the band-pass filter. This is the frequency where the gain is $1/2$ (-6dB) of the nominal gain. Increasing f_1 will "push" f_2 up if necessary to maintain the minimum bandwidth. See Table 8 for parameter limits.

BPf2: #####Hz

Specifies the upper cutoff frequency of the band-pass filter. This is the frequency where the gain is $1/2$ (-6dB) of the nominal gain. Decreasing f_2 will "push" f_1 down if necessary to maintain the minimum bandwidth. See Table 8 for parameter limits.

BPfcnt: #####Hz

Specifies the center frequency, $((f_1+f_2)/2)$ of the band-pass filter. Changing this parameter simultaneously shifts f_1 and f_2 up or down and is included for convenience. Setting the center frequency will not change the filter bandwidth. The full center frequency range is only available if the bandwidth is set to its minimum value. Conversely, if the bandwidth is set "high", then the center frequency will have a "small" tuning range. See Table 8 for parameter limits.

BPfwidth: #####Hz

Specifies the bandwidth, (f_2-f_1) of the band-pass filter. Increasing the bandwidth spreads f_1 and f_2 apart, but does not change the center frequency unless f_1 would violate its minimum setting or f_2 would violate its maximum setting. In this case, f_1 or f_2 would stop at the limit. See Table 8 for parameter limits. This parameter is included for convenience.

BPorder: ###x

Specifies the filter order of the FIR band-pass filter. Filter orders supported are from 3 to 128 taps for 2-channel mode, and 3 to 256 taps for 1-channel mode.

BPGain: ###.##x

See APGain above.

BandStop. Selects the digital FIR band-stop filter that passes signals with frequencies from DC to a specified frequency and from another specified frequency to bandwidth limits of the A/D and D/A chain, or about 21.6KHz for the 48KHz sampling rate.

BSf1: #####Hz

Specifies the lower cutoff frequency of the band-stop filter. This is the frequency where the gain is $1/2$ (-6dB) of the nominal gain. Increasing f_1 will “push” f_2 up if necessary to maintain the minimum stopband width. See Table 8 for parameter limits.

BSf2: #####Hz

Specifies the upper cutoff frequency of the band-stop filter. This is the frequency where the gain is $1/2$ (-6dB) of the nominal gain. Decreasing f_2 will “push” f_1 down if necessary to maintain the minimum stopband width. See Table 8 for parameter limits.

BSfcntr: #####Hz

Specifies the center frequency, $((f_1+f_2)/2)$ of the band-stop filter. Changing this parameter simultaneously shifts f_1 and f_2 up or down and is included for convenience. Setting the center frequency will not change the filter bandwidth. The full center frequency range is only available if the stopband width is set to its minimum value. Conversely, if the stopband width is set “high”, then the center frequency will have a “small” tuning range. See Table 8 for parameter limits.

BSfwidth: #####Hz

Specifies the stopband width, (f_2-f_1) of the band-stop filter. Increasing the bandwidth spreads f_1 and f_2 apart, but does not change the center frequency unless f_1 would violate its minimum setting or f_2 would violate its maximum setting. In this case, f_1 or f_2 would stop at the limit. See Table 8 for parameter limits. This parameter is included for convenience.

BSorder: ###x

Specifies the filter order of the FIR band-stop filter. Filter orders supported are from 3 to 128 taps for 2-channel mode, and 3 to 256 taps for 1-channel mode.

BSGain: ###.##x

See APGain above.

Notch. Selects the digital notch filter that passes all signals except the frequency specified for the notch. This filter is a second-order IIR filter with a zero response at the notch frequency and unity gain response at DC and $f_s/2$.

Nfnotch:#####Hz

Specifies the notch frequency of the filter. See Table 8 for parameter limits.

Nfwidth:#####Hz

Specifies the -3dB bandwidth of the notch filter. See Table 8 for parameter limits.

NGain: ###.##x

See APGain above.

InvNotch. Selects the digital inverse-notch filter (a band-pass filter) that passes signals with frequencies near the center frequency setting. This filter is a second-order IIR filter with unity gain at the center and with zeros in response at DC and $f_s/2$.

INfcntr: #####Hz

Specifies the center frequency of the filter. See Table 8 for parameter limits.

INfwidth:#####Hz

Specifies the -3dB bandwidth of the inverse-notch filter. See Table 8 for parameter limits.

INGain: ###.##x

See APGain above.

UserFIR. Selects the user-specified custom digital FIR filter. The coefficient values can be downloaded via the RS-232 port by using the “FUNC:UserFIR...” command described in the next section and in Table 5. Once the coefficients are downloaded they can be saved to the Versa-Filter’s internal memory (using the Store command) and later recalled without the need for a serial connection.

UFOder: ###

Specifies the filter order of the custom FIR filter. Filter orders supported are from 3 to 128 taps for 2-channel mode, and from 3 to 256 taps for the channel A only mode. When downloading coefficients via the RS-232 port, the UFOder value is automatically loaded.

UFtap:

Used to display the currently loaded FIR filter coefficients.

UFGain: ###.##x

See APGain above.

Global Parameter Descriptions

The parameters described in this section pertain to the Versa-Filter’s global parameters, display modes and the store and recall operations.

Levels:in- - out- -

Filter input and output signal levels are monitored when the “Levels” display is selected. The LCD shows four bar graph displays (in the position of the “-” symbol) that represent the peak levels of the two inputs and the two outputs. An input signal level equal to the “FullScalIn” setting corresponds to 0dB on the input VU meters. The indicators represent 9 levels with 6dB per level. A space character indicates -48dB or lower, a 1 bar high display indicates a level in the range (-48dB to -42dB). An “X” indicates a level greater than 0dB . Table 3 shows the signal level display bounds. The VU level displays are derived by passing the signals through a full-wave rectifier, a logarithm converter, and a fast-attack/slow-decay algorithm.

Table 3: VU Level Display

Signal Level	Display
$>0\text{dB}$	“X”
$(-6\text{dB to }0\text{dB}]$	8 bars
$(-12\text{dB to }-6\text{dB}]$	7 bars
$(-18\text{dB to }-12\text{dB}]$	6 bars
$(-24\text{dB to }-18\text{dB}]$	5 bars
$(-30\text{dB to }-24\text{dB}]$	4 bars
$(-36\text{dB to }-30\text{dB}]$	3 bars
$(-42\text{dB to }-36\text{dB}]$	2 bars
$(-48\text{dB to }-42\text{dB}]$	1 bar
$< -48\text{dB}$	blank

RevertToLevels: [Y, N]

When set to “Yes”, the LCD automatically reverts to the VU level meter after a delay of about 5 seconds. Turning or pressing the knob temporarily puts the display back into the normal mode for adjusting parameters. When set to “No”, the VU Level meter can be manually selected in the menu.

FullScalIn: ##Vpp

The system's full-scale peak-to-peak input voltage setting controls the gain of the input amplifier and DSP gain constant blocks shown in Figure 3. This parameter should be set to the lowest possible value that avoids input overload for a given input signal. This will ensure that the maximum dynamic range is available from the A/D converter. A full-scale input signal corresponds to the 0dB input level for the VU meters. There is up to an additional 6dB (not guaranteed) of headroom available

before actual signal clipping occurs and the “Overload” LED’s come on. This parameter can be set from 1V_{pp} to 20V_{pp} in 1 volt increments.

SampleRate: [8KHz, 48KHz]

This option selects the sampling rate of the DSP. At “8KHz” the maximum bandwidth of the system is about 3.6KHz (at the –6dB point) and the minimum transition width of the FIR filters are about 68Hz. At the “48KHz” sample rate, the maximum bandwidth of the system is about 21.6KHz and the minimum transition width of the FIR filters are about 410Hz.

InputSrc: [Analog, WtNoise]

Selects the input source of the filters. Choosing “Analog” uses the system’s analog inputs. Choosing “WtNoise” drives both filter inputs with white noise derived by a uniformly distributed pseudo-random sequence generator.

Mode: [A&B Common, A&BSeparate, Ch A Only]

Setting the mode to “A&B Common” will set both filter channels to the same function. When changing mode, the filter parameter values are automatically recalled from the common memory area.

Setting to “A&BSeparate” makes channel A and channel B fully independent. Parameters are recalled from memory area A for channel A, and memory area B for channel B. In this mode the “a” or “b” character will precede all function parameters on the LCD to indicate which channel is currently selected.

Setting to “Ch A Only” disables channel B so that higher filter orders may be selected for channel A. Filters up to 256-taps may be specified in this mode.

There are three separate memory areas that are used to hold the function parameter values: common, channel A, and channel B. When storing (recalling) all three parameter areas are saved (restored) independent of the current “Mode” setting.

Cascade Ch A&B: [Y, N]

Setting to “Yes” cascades the channel A function and the channel B function. Cascading is performed in the digital domain without intermediate analog conversions. Input A is the input to the cascade and Output B is the output from the cascade. Output A is still available as the intermediate output.

Master Mode: [Y, N] (Not Implemented)**Initialize: press**

Pressing the knob twice initiates the system initialization procedure. The user non-volatile memory is cleared and factory default settings are loaded for all filter and global parameters. The initialize operation may be canceled by turning the knob when presented with the “Press to Initial” message on the LCD

Store: # press

Store the system settings in non-volatile memory. Pressing the knob twice while the cursor in on the right side of the LCD initiates the “Store” command that saves all of the system’s function parameter values (channel A, channel B, and common settings) and all global parameter values to non-volatile FLASH memory for future recall. The store operation may be canceled by turning the knob when presented with the “Press to Store” message on the LCD. Five memory locations are available. Memory location 0 is special because it is automatically recalled on power-up.

Recall: # press

Recalls the previously stored system settings. Pressing the knob twice while the cursor in on the right side of the LCD initiates the “Recall” command that retrieves all of the system’s function parameter values (channel A, channel B, and common settings) and all global parameter values from non-volatile FLASH memory. The recall operation may be canceled by turning the knob when presented with the “Press to Recall” message on the LCD. Five memory locations are available. Memory location 0 is recalled on power-up.

Firmware: Vx.xx

Reports the firmware version. This is a read-only value.

Serial No: xxxxxx

Reports the system’s serial number. This is a read-only value. Every system has a unique serial number to allow multiple systems to reside on a common serial bus, and independently addressed by a PC.

Serial Command Format

The system may be controlled and queried using simple ASCII command strings sent via the RS-232 serial port. The serial commands use the same parameter names that are displayed on the LCD during manual operation. The parameter names and permissible values are detailed in the previous section.

All serial commands start with the attention header: “at”. The baud rate is detected and set within the systems with the arrival of the first “a” character after the system is powered up or reset. This baud rate should be used for all subsequent communications until power is cycled or a reset command is issued. After the “at” is sent, a system’s unique serial number should be sent or “all” should be sent to address all the Versa-Filter systems that may be in the daisy-chain.

Next, the parameter value should be set by sending a ‘**parameter: value**’ combination. Alternatively, the current value may be queried by sending just the ‘**parameter**’ portion, and the **value** is returned by the system via the serial port. The Versa-Filter command structure is detailed in Table 4 and Table 5.

Command strings are ignored if the current Mode and/or Function do not correspond to the transmitted command string. In fact, if the system is in an unknown state, it’s always best to send an “aat” and {Carriage Return}, followed by a **Mode** command, and then a **FUNC** command. The “aat” will set the baud rate and clear the command queue.

If a numerical value is out-of-range when setting a parameter, the value is hard limited at the minimum or maximum valid value. Commands are case insensitive. Any simple terminal program can be used to experiment using the examples below (turn on local echo since the Versa-Filter does not echo characters sent to it).

Examples of standard commands to **set** the system parameters:

aat{CR}	Detect the baud rate and prepare the systems to receive data
at all Mode:A&BSeparate{CR}	Put all systems in the A&BSeparate mode
at all aFUNC:LowPass{CR}	Set the channel A function of all systems to LowPass filter
at all aLPfcut: 14000{CR}	Set the cutoff frequency of all channel A’s LowPass filters to 14000Hz
at all bFUNC:BandPass{CR}	Set the channel B function of all systems to BandPass filter
at all bBPfcnt: 1550{CR}	Set the center frequency of all channel B’s BandPass filters to 1550Hz
at sn:301125 bBPgain: 1.55{CR}	Set the specific system’s channel B, BandPass filter gain to 1.55x
at sn:301001, 301002 InputSrc:WtNoise{CR}	Set the two specific systems’ input sources to internal white noise generator
at sn:301125 Store:0{CR}	Store the specific system’s current settings into it’s internal memory location 0
at all levels:{CR}	Set all the systems displays to VU level mode

Examples of using commands to **query** the system parameters are:

at sn:301125 func{CR}	Specific Versa-Filter sends the current function setting
at sn:301001 LPfcut{CR}	Specific Versa-Filter sends the LowPass filter cut-off frequency setting
at sn:301001 SampleRate{CR}	Specific Versa-Filter sends the SampleRate setting

Examples of **extended commands** are:

at all reset{CR}	Reset all systems parameters to factory default values
at all display:Hello, World{CR}	Displays “Hello, World” on all displays
at all sendsn{CR}	All systems sends it’s unique serial number (with check sums) after a random delay
at sn:312001,312002, 312003 quietsn{CR}	Quiets specific systems from responding to the “sendsn” command

Custom filter example to download a 20th order FIR differentiator into the Versa-Filters and save into common memory:

at all Mode:A&B Common	Put all systems in A&B Common mode
at all FUNC:UserFIR: -74 111 -76 88 -117 170 -276 536 -1480 13285 -13285 1480 -536 276 -170 117 -88 76 -111 74{CR}	Set the function to UserFIR and downloads a 20-tap FIR differentiator
at all Store:1{CR}	Store the all systems’ settings into internal memory location 1 (includes filter coefficients)

Table 4: Serial Command Format

“at MODULE_ID COMMAND {CR}”		
“at”		Attention header required at the beginning of every command. The first “a” received after power is applied (or reset command is issued) is used for automatic baud rate detection.
MODULE_ID	“all” or “sn:serial# [,serial#]”	Addresses all modules connected to system. Addresses only the system(s) in the list. where: serial# = six digit serial number.
COMMAND	Standard command or Extended command	A standard command is any parameter:value combination that is displayed on the system’s LCD during manual operation, such as: “aBPf1: 1000Hz”. The trailing units at the end of a value are ignored (such as Hz). If the value is omitted, the system’s current setting is returned via the serial port. Table 5 lists the extended commands.
{CR}	Carriage Return	Required for all commands unless otherwise stated. The command is not executed until the carriage return is sent.
<p>Notes:</p> <ol style="list-style-type: none"> 1. If the system is in an unknown state, send an “aat” {CR} to set the baud rate (if not) and clear the command queue. 2. Command strings are ignored if the currently set Mode and/of Function do not correspond to the command string. 3. Commands are case insensitive unless otherwise specified. 4. The serial command string is parsed by the system as it arrives. 5. The backspace character is not supported in the input stream. 6. An error in the input stream will reset the system’s command parser. The system will then respond to the next valid header (“at”) to signal the start of a new command. 		

Table 5: Extended Commands

Extended Command	Description
reset	Writes the factory default parameter values in volatile memory and resets the auto-baud detection logic. FLASH memory is not affected. Use the “Initialize” command to reset FLASH memory.
sendsn	Commands the system(s) to send it’s 6-digit serial number with appended check sum digits. The result is a 10-digit ASCII number defined below. The systems wait a random amount of time (up to 1 second) before sending a response so collisions are minimized when multiple systems are responding. A valid response consists of the 6-digit serial number followed by the 4-digit check sums: #####oess, with ##### - 6-digit Serial No. (e.g. 324327) o - check sum of the odd digits (modulo 10) (e.g. 3+4+2 = 9) e - check sum of the even digits (modulo 10) (e.g. 2+3+7 (mod 10) = 2) ss - check sum of #####oe (e.g. 3+2+4+3+2+7+9+2 = 32) The resulting serial number returned is #####oess (e.g. 3243279232).
quietsn	Quiets a system(s) from responding to sendsn. To unquiet, use the reset command.
display:[text to display]	Displays text on the system’s LCD (up to 16 characters). The LCD is cleared and the text between the “:” and final {CR} is displayed. The case of the text string is passed to the LCD.
display:	The display command without a text string sets the system display back to normal and positions the cursor to the left.
func: UserFIR: # # # ... afunc: UserFIR: # # # ... bfunc: UserFIR: # # # ...	<p>This command downloads FIR filter coefficients to the system and sets it to the UserFIR function. The coefficients are downloaded to one of three memory areas (common, channel A, or channel B) as indicated by function specification (“func”, “afunc”, or “bfunc” respectively). The minimum filter order is 3, and the maximum is either 128 or 256 depending on the system’s current mode setting.</p> <p>The numbers must be entered as integers in the range of [-32768 to 32767], corresponding to filter coefficient values in the range: [-1 to 1). The filter order, “UForder:” is automatically set to the number of coefficients in the list. The coefficients are downloaded to the specified memory area independent of the current mode setting.</p> <p>4-tap example: “at all func:userfir: 500 30000 -30000 -500{CR}”</p>

Basic Versa-Filter Specifications

The specifications of the two channel Versa-Filter system is given in Table 6. Detailed specifications of the Versa-Filter Module, on which the filter system is based on, are given in Table 8.

Table 6: Versa-Filter System Specifications

Inputs and Outputs	Two single-ended inputs and two single-ended outputs on BNC connectors
Input Levels	1 Vpp to 20Vpp full-scale (saturable in 1 vpp increments)
Input Impedance	~80K Ohms
Output Level	0 to 22Vpp
Output Impedance	100 Ohms
Signal Coupling	AC or DC coupling (jumper selectable)
Filter Types	Linear Phase FIR: Low-pass, High-pass, Band-pass, Band-stop (3 to 128 taps, or 3 to 256 taps in single channel mode) 2nd order IIR: Notch, Inverse-Notch Other: User downloadable FIR filter coefficients (to 256 taps)
Filter Response	Response: DC to 20KHz (fs=48KHz), DC to 3.3KHz (fs=8KHz) Stop-band Attenuation: -70 dB Pass-band Ripple: ± 0.2 dB Transition Width (256 taps): 410Hz (fs=48KHz), 68Hz (fs=8KHz)
Gain	0x to ± 100 x in steps of 0.01x
Distortion (THD)	0.03% typical, 0.04% max.
Remote Control Ports	Two RS-232 serial ports for daisy-chaining multiple systems. DB-9F for computer connection, DB-9M for downstream.
Display	1-line by 16-character liquid crystal display
Power Supply	Wall mount, 115VAC input (optional 95VAC-250VAC universal input supply), Outputs: 5V, +12V, -12V
Packaging	Bench-top aluminum chassis with rubber feet and front tip-up stand
Dimensions	10" wide x 2.75" high (2.25" excluding feet) x 8.1" deep
Weight	3 lbs. (filter system), 1.5 lbs. (wall mount power supply)

Circuit Schematics

Figure 2 shows the circuit schematic of the 2-channel Versa-Filter System. It includes input buffer amplifiers and output buffer amplifiers that swing at least 22Vpp. AC or DC signal coupling is supported by setting the jumpers as shown in the figure. The arrangement of the dual diodes D4 and D5 allow the computer to talk and listen to all modules and systems in the chain. An unlimited number of Versa-Filter Systems may be daisy-chained through the RS-232 connectors P1 and P2. The speaker provides acoustic feedback in the form of clicks and beeps for the rotary encoder when setting the parameters.

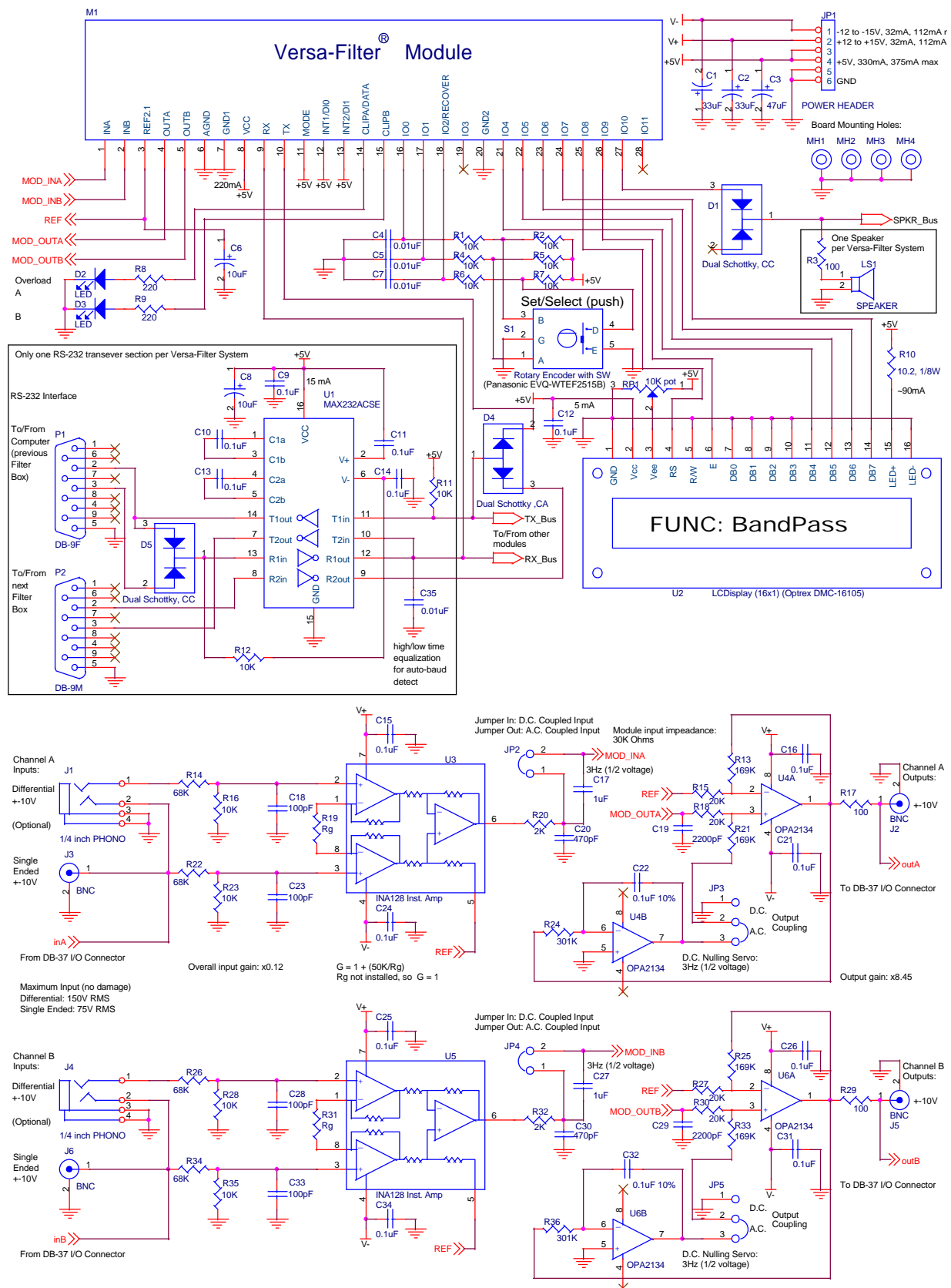

Figure 2: 2-Channel Versa-Filter System. AC or DC coupling may be selected with jumpers.

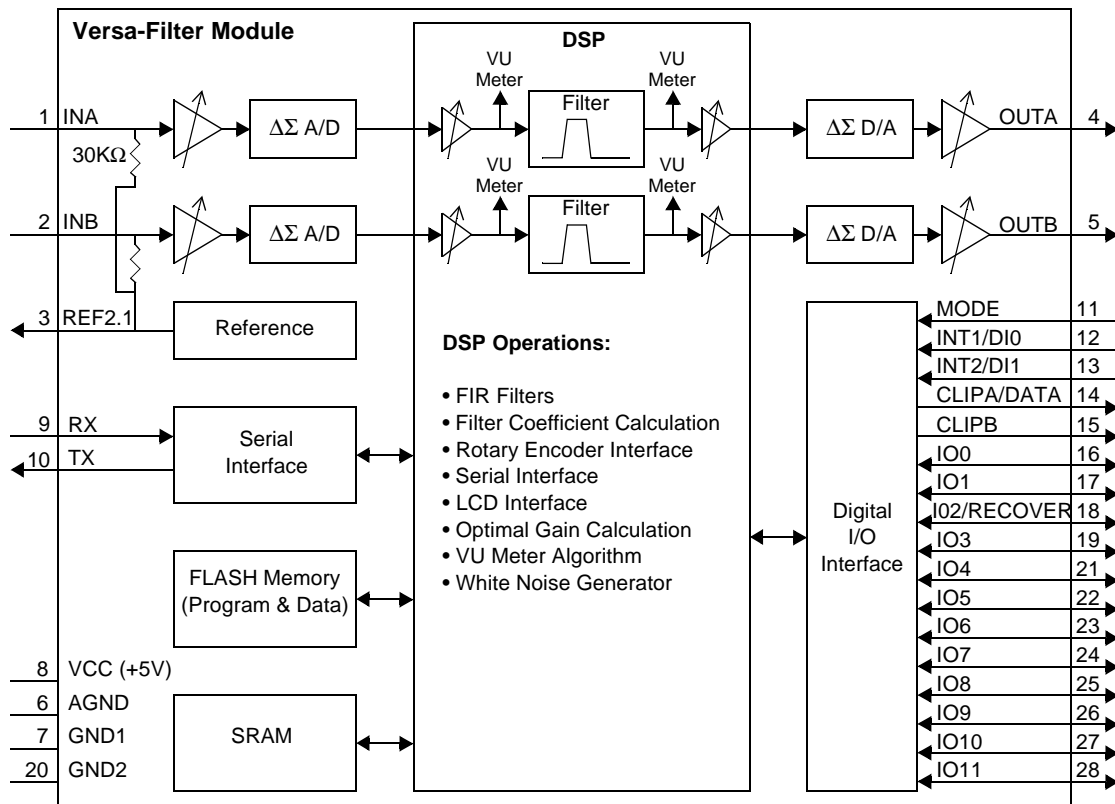

Figure 3: Functional Block Diagram of Versa-Filter Module

Module Block Diagram Description

Figure 3 shows the functional block diagram and pin assignments of the Versa-Filter Module that forms the heart of the 2-channel Versa-Filter System. The analog inputs consist of programmable gain amplifiers followed by Delta-Sigma analog-to-digital converters with built-in anti-aliasing filters. The converters reside in a 16 bit CODEC chip. The input full-scale voltage setting of the system sets the gain of the input amplifiers so the input will not overflow. A second or fine scale factor is applied after the A/D so that the VU meter indicates 0dB when full-scale input level is applied. There is up to 6dB of additional headroom over the full-scale voltage setting before clipping occurs. Hard input signal clipping is indicated by the CLIPA and CLIPB output pins that are tied to the LEDs.

The analog output consists of Delta-Sigma digital-to-analog converters and a programmable attenuator. The optimal output gain distribution is calculated by the DSP and is based on the gain parameter setting in the system. The coarse and fine gains are automatically set so that the D/A bits are maximally loaded. Standard sampling rates supported by the system are 48KHz and 8KHz. An internal clock generator supplies the sampling and DSP clocks.

The DSP realizes the filter functions and computes the filter coefficients as the filter order or frequencies are adjusted. Other DSP functions include the serial command interpreter, rotary encoder interface, LCD interface, VU meter algorithm, and noise generator. The pin description details for the Versa-Filter Module are given in Table 7.

Table 7: Versa-Filter Module Pin Descriptions

Pin#	Signal Name	In/ Out	Description
1	INA	I	Analog input A. Internally biased to REF2.1 voltage with 30K Ω resistor when powered. The typical full-scale input voltage is 2.8Vpp centered on REF2.1.
2	INB	I	Analog input B. Internally biased to REF2.1 voltage with 30K Ω resistor when powered. The typical full-scale input voltage is 2.8Vpp centered on REF2.1.
3	REF2.1	O	2.1V nominal reference output voltage source for biasing external analog circuits. The reference output should be buffered for all AC loads and for DC loads more than 400uA.
4	OUTA	O	Analog output A. Centered around the REF2.1 voltage. An internal 600 Ω series resistor forms the output filter in conjunction with an external 2200pF shunt capacitor. External load impedance should be 10K Ω or more.
5	OUTB	O	Analog output B. Centered around the REF2.1 voltage. An internal 600 Ω series resistor forms the output filter in conjunction with an external 2200pF shunt capacitor. External load impedance should be 10K Ω or more.
6	AGND	-	Analog Ground. Internally connected to GND1 and GND2.
7	GND1	-	Digital Ground. Internally connected to AGND and GND2.
8	VCC	-	+5V power supply input
9	RX	I	TTL level asynchronous serial receive pin
10	TX	O	TTL level asynchronous serial transmit pin
11	MODE	I	TTL level input to set the operating mode of the Versa-Filter. Connect to VCC for normal operation. Normal mode makes IO4-IO11 outputs for connection to the LCD. Logic 0 on this pin makes IO4-IO11 inputs (reserved for future use).
12	INT1/DIO	I	Reserved, connect to VCC.
13	INT2/DI1	I	Reserved, connect to VCC.
14	CLIPA/DATA	O	This digital output goes high when there is an overload on channel A. Overload occurs when the analog input exceeds the input range setting of the A/D. This output also goes high when the module is accessing it's internal FLASH data memory such as when storing or recalling settings.
15	CLIPB	O	This digital output goes high when there is an overload on channel B. Overload occurs when the analog input exceeds the input range setting of the A/D.
16	IO0	I/O	Quadrature rotary encoder input B. Accepts gray code digital input to set the module parameters. This bit should transition <u>at</u> the dented stop positions of the rotary encoder.
17	IO1	I/O	Quadrature rotary encoder input A. Accepts gray code digital input to set the module parameters. This bit should transition <u>between</u> the dented stop positions of the rotary encoder.
18	IO2/RECOVER	I/O	Push button switch input from the rotary encoder to position the cursor. If this pin is low at power-up, alternate firmware is booted that allows only firmware reprogramming. IMPORTANT: Do not change the level of this pin while reprogramming the firmware.
19	IO3	I/O	Reserved, leave unconnected.
20	GND2	-	Digital Ground. Internally connected to AGND and GND1.
21	IO4	I/O	Drives LCD pin 11 (D4).
22	IO5	I/O	Drives LCD pin 12 (D5).
23	IO6	I/O	Drives LCD pin 13 (D6).
24	IO7	I/O	Drives LCD pin 14 (D7).
25	IO8	I/O	Drives LCD pin 4 (RS).
26	IO9	I/O	Drives LCD pin 6 (E).
27	IO10	I/O	Digital output for speaker that produces optional acoustic feedback for setting module parameters.
28	IO11	I/O	Reserved, leave unconnected.

Electrical Specifications:

Table 8: Versa-Filter Module Specifications

($T_A = 25^\circ\text{C}$, $V_{CC} = 5.0\text{V}$, $f_s = 48\text{KHz}$, Measurement bandwidth is 10Hz to 20KHz unless otherwise specified.)

Parameter	Min.	Typical	Max	Units
Basic Characteristics:				
Power Supply Voltage	4.8	5.0	5.3	V
Power Supply Current		220	270	mA
Operating Ambient Temperature	0		70	$^\circ\text{C}$
Total Harmonic Distortion		0.03	0.04	%
Gain Matching (after calibration)			0.05	dB
Phase Matching (after calibration)			0.02	degrees.
Sampling Rate	$f_s = 8\text{KHz}$ or 48KHz (user selectable)			
Filter Response Characteristics:				
Stopband Attenuation (LP, HP, BP, BS FIR Filters)	-68	-70		dB
Filter Transition Width (-6dB to -70dB)	$f_s = 48\text{KHz}$, 256 taps	410	420	Hz
	$f_s = 48\text{KHz}$, 128 taps	820	840	Hz
	$f_s = 8\text{KHz}$, 256 taps	68	70	Hz
	$f_s = 8\text{KHz}$, 128 taps	136	140	Hz
AllPass Mode Delay (assumes no input and output RC filters)	$\frac{22}{f_s}$	Max: $\frac{22}{f_s} + (12e - 6)$		sec.
FIR Filter Delay (assumes no input and output RC filters) $N =$ filter order (3 to 256)	$\frac{22 + \frac{N}{2}}{f_s}$	Max: $\frac{22 + \frac{N}{2}}{f_s} + (12e - 6)$		sec.
Passband Ripple	Digital Filter	± 0.003	± 0.005	dB
	Digital Filter with CODEC		± 0.2	dB
Filter Frequency Set Ranges: for $f_s = 48\text{KHz}$, LP and HP, fcut: BP and BS, f1: f2: fwidth: notch, inv-notch, fcenter: fwidth: for $f_s = 8\text{KHz}$, LP and HP, fcut: BP and BS, f1: f2: fwidth: notch, inv-notch, fcenter: fwidth:	200		20,000	Hz
	200		19,600	Hz
	600		20,000	Hz
	400		19,800	Hz
	200		20,000	Hz
	10		10,000	Hz
	33		3,333	Hz
	33		3,266	Hz
	66		3,333	Hz
	66		3,300	Hz
	33		3,333	Hz
	1		1,666	Hz
Analog Input Characteristics: (Minimum input gain setting; unless otherwise specified)				
A/D Resolution	16			Bits
A/D Differential Nonlinearity (Note 1)			± 0.9	LSBs
A/D Instantaneous Dynamic Range	80	84		dB
A/D Total Harmonic Distortion		0.01	0.02	%
Frequency Response (Note 1)	-0.5		+0.2	dB
Input Gain Drift (Note 1)			100	ppm/ $^\circ\text{C}$
Input DC Offset Error			± 50	LSBs
Full Scale Input Voltage	2.5	2.8	3.1	V _{pp}
Input Resistance (Note 1)	20K	30K		Ω
Input Capacitance (Note 1)			15	pF

Table 8: Versa-Filter Module Specifications(T_A = 25°C, VCC = 5.0V, f_s = 48KHz, Measurement bandwidth is 10Hz to 20KHz unless otherwise specified.)

Analog Output Characteristics: (Module gain setting of 1; unless otherwise specified)				
D/A Resolution	16			Bits
D/A Differential Nonlinearity (Note 1)				
D/A Total Dynamic Range		93		dB
D/A Instantaneous Dynamic Range	80	83		dB
D/A Total Harmonic Distortion (10KΩ, 100 pF load)		0.01	0.02	%
Frequency Response (Note 1)	-0.5		+0.2	dB
Output Gain Drift (Note 1)			100	ppm/°C
REF2.1 Output Voltage (max. output current=400μA) (REF2.1 must be buffered to drive dynamic loads. AC variations in REF2.1 current may degrade ADC and DAC performance.)	1.9	2.1	2.3	V
Output DC Offset Voltage (no DC load)		10		mV
Full Scale Output Voltage (10KΩ, 100 pF load)	2.4	2.7	3.1	Vpp
External Load Impedance	10K			Ω
Internal Resistor Value for OUTA and OUTB	400	600	800	Ω
Out of Band Energy (22KHz to 100KHz)		-60		dB
Note 1: This specification is guaranteed by characterization, not production testing. Specifications are subject to change without notice.				